

Daylight availability and Cooling in Commercial Buildings - The Influence of Facade Design

Ph.D HENDRIK VOLL; TEET-ANDRUS KOIV
ENVIRONMENTAL ENGINEERING
TALLINN UNIVERSITY OF TECHNOLOGY
EHITAJATE TEE 5
19086 TALLINN
ESTONIA
Hendrik.voll_@ttu.ee <http://www.ttu.ee/>

Abstract: - The modern design of office buildings shows a tendency to increase the window share per facade to be more impressive with grand visibility and well daylit rooms. An increased window share in general results in an increased use of energy and costs for cooling, but these disadvantages can be reduced with a more careful design. The aim of this paper is to show the influence of window design and room layout on cooling demand and daylight availability in office buildings in Northern Europe.

The results in the paper are based on design calculations for two different room types and daylight measurements on two room scale models in a daylight laboratory. Calculations show the influence of window design parameters on the cooling demand. The daylight measurements show the influence of window design parameters on the availability for daylight. The results have then been combined to show feasible window design regarding daylight availability and resulting cooling demand for different window orientations.

The results show that, in most cases, it is possible to find a combination of window share and window solar factor that is feasible from daylight as well as cooling point of view. The main finding is that there is a smaller or wider range of feasible design for different window orientations. Here, the product of window share and solar factor is introduced as a guideline to find feasible designs.

Key-Words: - Commercial buildings, window share, solar factor, cooling demand, daylight.

1 Introduction

Daylighting of buildings by using the diffuse rays of the light from the sun as the primary light source has been bestowed a great deal of research in the last five to ten years [9]. These studies have indicated positive effects of daylight on students, shoppers and office workers health and productivity [8], [12], [13]. Daylit buildings seem to increase human performance, partly because people enjoy such spaces and will stay a little longer and return more frequently to their work place or, when shopping, to the shop[1].

In rooms with windows in exterior walls, it is often solar irradiation that accounts for the greater part of the internal heat surplus. The size of the windows and how they are shaded are therefore often major deciding factors when determining the size, capacity and cost of the HVAC system [3].

The main objective of the paper is to show the influence of design window parameters and room layouts on the cooling power demand and the daylight availability in office rooms. The hypothesis is that there are certain combinations of window sizes and window types that are more feasible than other combinations, from an economic as well as a daylight point of view. The paper is based on the findings in the PhD thesis of the first author of this paper[5]. The study is focused on glazed buildings without external shadings and on conditions valid for latitudes around 57° ~ 60° in North and North East European locations.

2 Cooling Demand Simulations

When the heat from the solar irradiation, people, office equipment and electrical lighting exceeds the heat loss at the highest accepted room temperature, there is a heat

surplus that has to be removed. The cost of the system installed to remove the heat surplus depends on the greatest cooling load that it has to deal with, the design load[4].

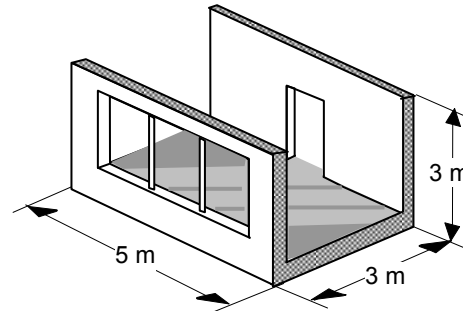
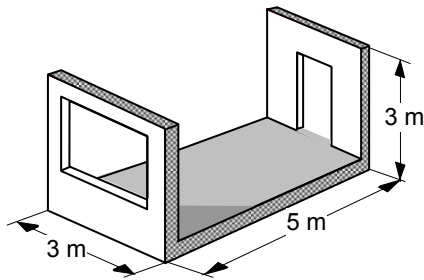

Fig. 1 Left picture: office room type 1, Right picture: office room type 2[6]

Room type 1 represents a typical office room layout and type 2 a more extreme layout regarding window size per room. The solar factor g (sometimes also called the shading coefficient) is the ratio of solar heat gain

through a glazing to the solar heat gain through a single clear glass. The smaller the number, the better the glazing is to preventing solar heat gains but poorer to let natural daylight inside the room[7].

Some typical solar factor g values are shown below [14], [15].

Unprotected triple-glazed window	$g \approx 0.7$
Solar protected glass	$g \approx 0.4$
Mirror glass window	$g \approx 0.2$

In office room simulations the following values were used. U-values: Facade wall $0.27 \text{ W}/(\text{m}^2\text{K})$; Window $1.6 \text{ W}/(\text{m}^2\text{K})$; Ceiling $0.15 \text{ W}/(\text{m}^2\text{K})$. Installed lighting power $10 \text{ W}/\text{m}^2$, office equipment $10 \text{ W}/\text{m}^2$, and people $6 \text{ W}/\text{m}^2$. It is presupposed that the room temperature is not allowed to exceed $+25^\circ\text{C}$ during more than 80 working hours per year[6].

The diagrams in figure 2 show how the size of the glass area per facade and the solar shading of the window affect the capacity and the cost of the HVAC system in a type 1 office room. The heat surplus is supposed to be mastered by means of chilled beams[4], [6]. Figure 2 also shows how the cost of the chilled beam system

will increase in relation to a standard case. The standard case assumption is an office building where the windows cover 30% of the facade and the solar factor is 0.3. The total cost of the distribution system is primarily dependent on the size of the building and its design but only marginally affected by the size of the design loads. The cost for the chilled beams and the chiller however is strongly influenced of the design load.

A more complete and detailed presentation showing the influence of the shape of the room, the window orientation, the window size and the solar factor for required cooling capacity is given by H.Voll[5], [6].

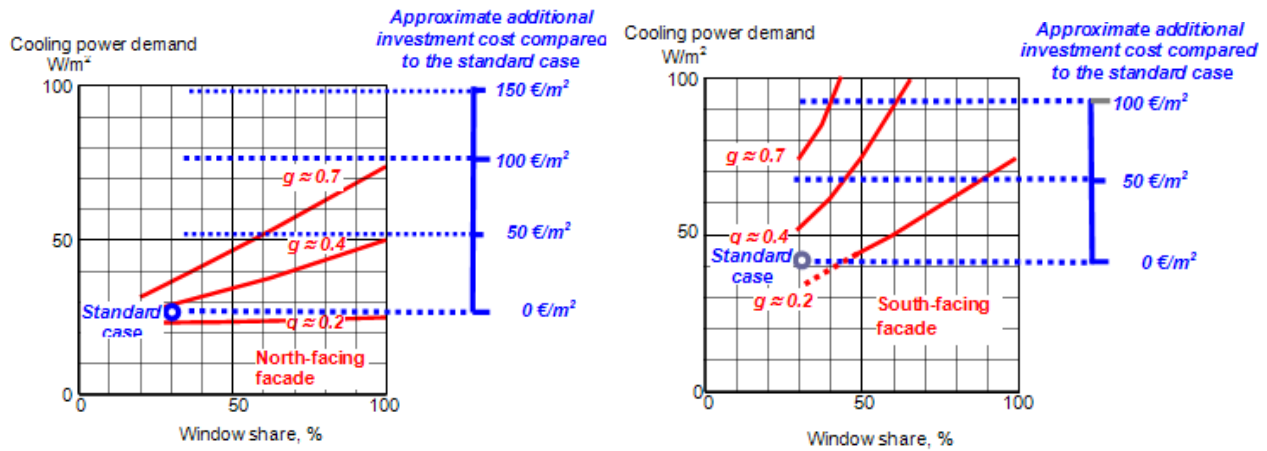

Figure 2 Left figure: a type 1 office room with a south-facing facade. Right figure: a type 1 office room with a north-facing facade. In both cases a chilled beam system masters the heat surplus.

A cooling power demand over 100 W/m² implies an HVAC system with a considerable capacity[1]. It seems justifiable to question if ordinary office building in North European circumstances, latitude about 57 ~ 60° should

really be designed in such way that the cooling power demand exceeds 100 W/m². Table 1 gives an overview of the possible glass share per facade (window shares) for room type 1 and 2 without exceeding a maximum cooling power demand of 100 W/m² level.

Table 1 Possible window shares per facade for different window solar factors for room type 1 and 2 without exceeding a maximum cooling power demand of 100 [W/m²].

Window solar factor g	East, %		South, %		West, %		North, %	
	Room 1	Room 2	Room 1	Room 2	Room 1	Room 2	Room 1	Room 2
$g = 0.2$	95	95	95	95	95	95	95	95
$g = 0.4$	95	70	65	45	75	50	95	95
$g = 0.6$	65	45	45	35	55	35	95	95
$g = 0.74$	50	35	35	20	45	25	95	90

Furthermore, Figure 3 shows the possible window shares for different maximum cooling power demands (50, 75 and 100 W/m²) as function of solar factor for room type 1 and 2 north and south orientations.

The lines in Figure 3 show the relation between the window share and the solar factor resulting in the same maximum cooling power demand. This relation, in form of the product, is in most cases close to a constant value. This means e.g. that a combination with 60% window share and a solar factor of 0.4 will give quite similar

cooling power demand as 40% window share and a solar factor of 0.6, as the product of the two are the same in both cases.

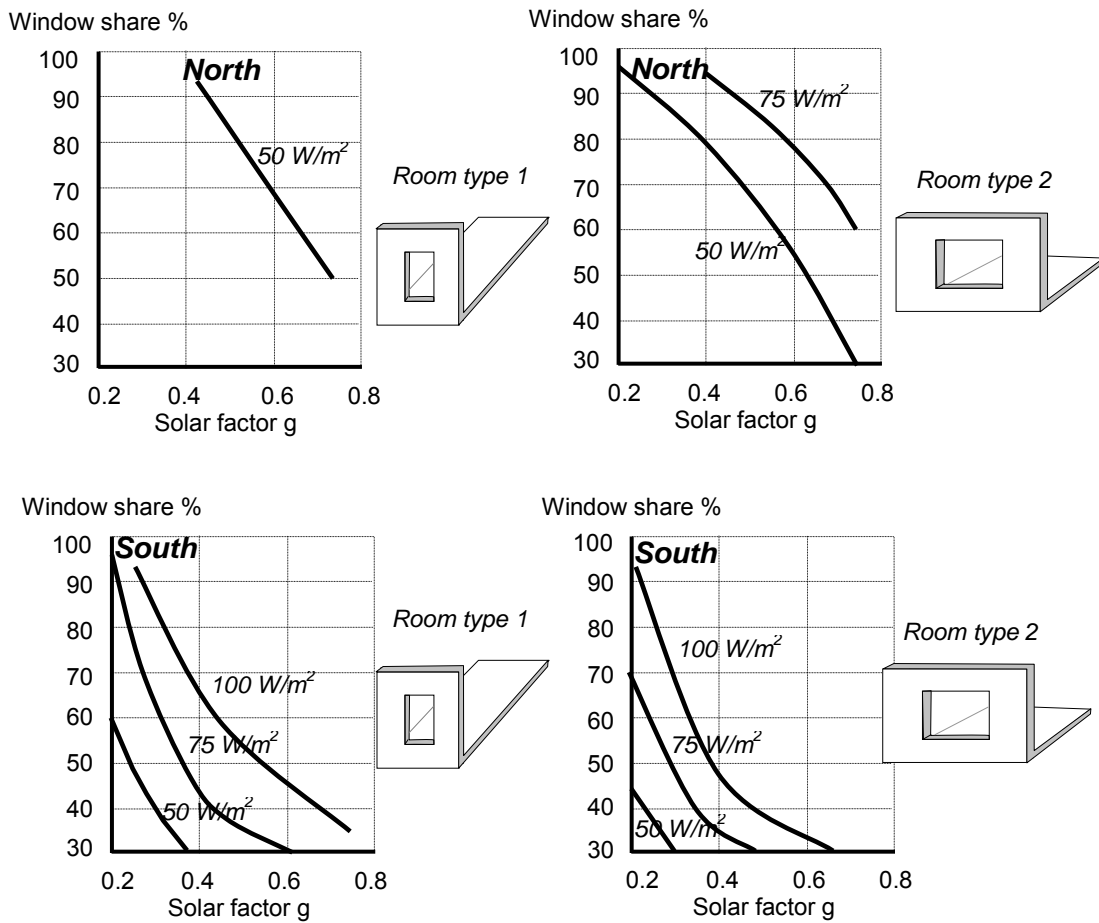

Figure 3 Possible window glass share and solar factor combination for room type 1 and 2 for maximum cooling power demand 50, 75 or 100 W/m².

Table 2 shows the product of window glass share and solar factor for different maximum cooling power demands 50, 75 and 100 W/m².

Table 2 Typical values of the product of the window share per facade and the solar factor for a maximum cooling power demand of 100, 75 and 50 [W/m²].

Cooling power demand, W/m ²	East		South		West		North	
	Room 1	Room 2	Room 1	Room 2	Room 1	Room 2	Room 1	Room 2
100 W/m ²	0.38	0.28	0.27	0.19	0.33	0.21	0.70	0.66
75 W/m ²	0.30	0.20	0.19	0.14	0.25	0.16	0.70	0.48
50 W/m ²	0.20	0.14	0.12	0.09	0.15	0.12	0.42	0.33

The product of window share and solar factor varies in between 0.09 (south facing window and a cooling demand of 50 W/m²) and 0.7 (north and 100 W/m²).

For north orientations the product of window share and solar factor for a certain maximum cooling power demand could be much larger compared to all other orientations.

The south orientation has the highest maximum solar irradiation in both W/m^2 and Wh/m^2 and therefore results in the highest cooling demands. South orientations therefore require a careful choice of window glass area and solar factor. To keep the cooling power demand below $50 W/m^2$

3 Daylight Tests

Tests conducted at Seattle Daylighting Lab show how different solar factors and window sizes influences the daylight availability inside a type 1 or 2 office room. The Daylighting Lab in Seattle has a mirror-box overcast sky for the analysis of physical scale models at all stages of the design process. The mirror-box overcast sky conforms to the "International Overcast Sky". The shadowless artificial overcast sky

$$DF = 100 \times (E_{in} / E_{ext}) \quad (1)$$

Where,

DF; The daylight factor, [%],

E_{in} ; Inside illuminance at a fixed point, [lx],

E_{out} ; Outside horizontal illuminance under an overcast sky, [lx] [1].

Rooms in buildings at different locations require different daylight factors to be daylit. In Northern Europe spaces with a lowest daylight factor of 2 or above give us a feeling of daylit space[11]. Office spaces with a lowest daylight factor below 2 would probably feel dark even during summer overcast days and would require electrical light(s) to be on. If the difference between the highest and lowest daylight factor in a space exceeds about 20 the space might feel gloomy[11].

The models of room type 1 and 2 built is in scale 1:10 of the original size, with interchangeable parts to test multiple floor and facade

for south orientation the product of window share and solar factor must be about 0.1 or below.

The combination of window glass share and solar factor feasible for east and/or west facade is in between the values for north and south.

condition created in mirror-box is a test condition defined by the international commission of illumination (CIA). The shadowless sky is generally three times brighter at zenith (directly overhead) than it is at the horizon[1].

The daylight factor describes the ratio of inside illuminance over outside illuminance at a specific point, expressed in percent[1].

alternatives. For floor, wall, ceiling black foam core was used. The interior of the model was finished by matt color paper that was glued on the foam core. The floor was covered with 20% reflective, dark gray paper. Reflectance for walls was 60% and for ceiling 80% by choosing light color paper. Finally all the edges and corners were taped with black tape to avoid glowing seams inside the model.

For both room type four different facade layouts with 15%, 30%, 50% and 80% of window (glass) area were studied.

Figure 4 shows one of the models used for daylight tests.

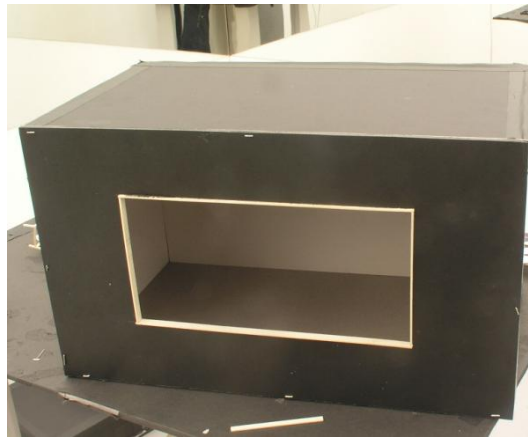

Figure 4 Scale model of room type 2.

Six photocells were used to measure the percentage of available daylight in September noon overcast condition. One "control cell" was placed on top of the model oriented towards zenith to measure the amount of available daylight. Inside the model, five photocells were placed on work zone height (0.85 m original scale I^{0-}) to measure the amount of light reaching the interior. The photocells inside the room were moved to different positions in parallel with the window facade. For both room types and each window glass area 50 daylight factor readings were measured. The interior readings were then divided by the exterior reading, directly giving the daylight factor. Measured daylight factors in the laboratory for room type 1 and 2 scale models are

presented in Table 3. The first value in the table is the highest measured daylight factor in the room and the second the lowest. The bold values in the table indicates the lowest daylight factor in the room is 2 or above. The values written in italic indicate a daylight factor below 2. The values written in bold and italic respond to the situation where the difference between the highest and lowest daylight factor in the room exceeds 20. The daylight factor is measured for September overcast conditions and the results are valid for all orientations since the reference sky is independent of the geographical latitude of the investigated space.

Table 3 Overcast study results for September for office room types 1 and 2. Daylight factor values for different facade sizes and solar factors.

Window solar factor g	DF, window 15%		DF, window 30%		DF, window 50%		DF, window 80%	
	Room 1	Room 2	Room 1	Room 2	Room 1	Room 2	Room 1	Room 2
$g = 0.2$	<i>3-0</i>	<i>5-0</i>	<i>5-0</i>	<i>6-1</i>	<i>6-0</i>	<i>6-1</i>	<i>7-1</i>	<i>7-2</i>
$g = 0.4$	<i>6-0</i>	<i>9-1</i>	<i>10-1</i>	<i>10-1</i>	<i>11-1</i>	13-2	14-2	15-4
$g = 0.6$	<i>9-0</i>	<i>11-1</i>	<i>15-1</i>	17-2	17-2	19-3	20-2	23-6
$g = 0.7$	<i>12-1</i>	18-2	<i>19-1</i>	22-2	24-2	26-4	29-3	30-7

The results presented in Table 3 can also be illustrated in accordance with Figure 5. Figure 5

shows the results for both room types for fulfilling the requirement: the daylight factor

should be 2 or above and the difference between the highest and lowest daylight factor should be below 20. If these requirements are to be fulfilled, the window glass share and solar factor combination must lay within the marked light grey area. The hatched area below that area indicated as “dark” means the lowest daylight factor in the room would be below 2. The area indicated as “gloomy” means the contrast between the lowest and highest daylight factor exceeds 20. Thus the line separating the “daylit” area and “dark” area shows the minimum possible combinations of window glass share and solar factor for fulfilling the daylight requirements. This combination is historically

just referred to as the product of the window glass share and the solar factor.

To fulfil the daylight requirements in room type 1 this product should be ≥ 0.24 and for room type 2, ≥ 0.16 .

The line separating the “daylit” and “gloomy” area shows the limits for possible combinations of window glass share and solar factor for fulfilling the daylight requirements without risk of a gloomy space. The product of window glass share and solar factor should therefore be 0.33 or below for both room types. Combinations with a product above that value might otherwise lead to gloomy space.

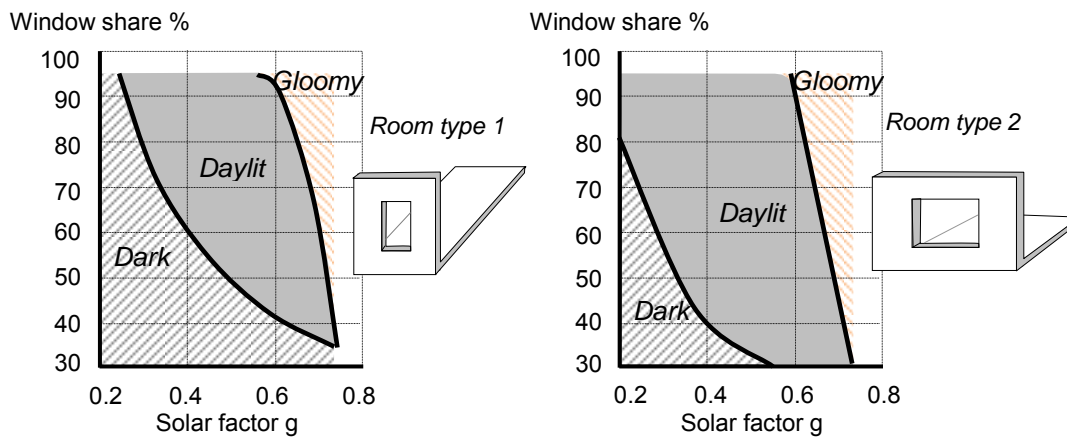

Figure 5 Possible window glass share and solar factor combinations for fulfilling the requirements: The daylight factor should be 2 or above and the difference between the lowest and highest daylight factor must not exceed 20. The result is valid for all orientations.

4 Cooling Demand and Daylight

Table 4 shows possible window shares for office room type 1 and 2 that fulfills both the cooling and daylight requirements: the maximum cooling power demand should not exceed 100 W/m², the lowest daylight factor should be 2 or

above and the difference between the highest and lowest daylight factor should be below 20. The blank cells in Table 4 indicate that the daylight factor in the room is below 2.

Table 4 Possible window shares for type 1 and 2 office rooms that fulfill both the cooling and daylight requirements: the dimensioning cooling load should not exceed 100 W/m² and the daylight factor should be above 2 and the difference between the highest and lowest daylight factor should be below 20.

Window solar factor g	East, %		South, %		West, %		North, %	
	Room 1	Room 2	Room 1	Room 2	Room 1	Room 2	Room 1	Room 2
g = 0.2	-	80-95	-	80-95	-	80-95	-	80-95
g = 0.4	75-95	50-75	60-65	40-45	60-75	40-50	60-95	40-95
g = 0.6	50-65	25-45	40-45	25-30	40-50	25-35	40-95	25-95
g = 0.74	35-45	15-30	30	15-20	40-45	15-25	35-45	15-30

In Figure 6 these table values of possible combinations of window glass share and solar factor for a north and south orientated room type 1 and 2 is shown in graphical form. If both cooling and daylight requirements are to be fulfilled, the window share and solar factor combination must lay within the marked grey

area. Combinations below that area indicates a daylight factor below 2 and thereby “dark” room. Combinations above the grey area indicate a cooling power demand above 100 W/m² and in some cases the risk of gloomy room due to a too large illuminance contrast.

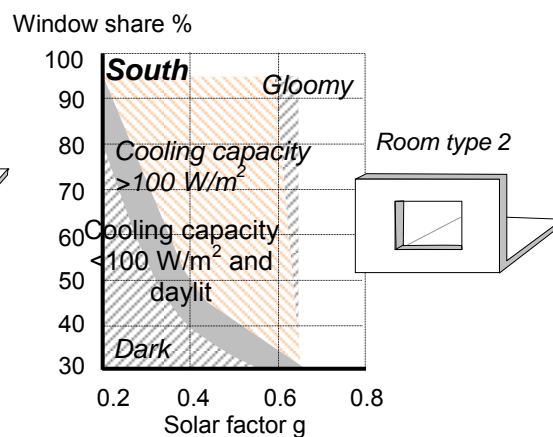
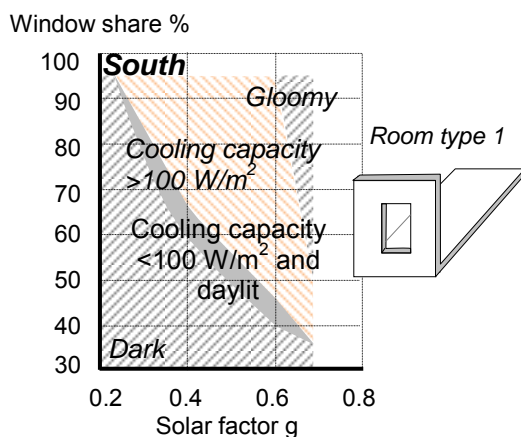
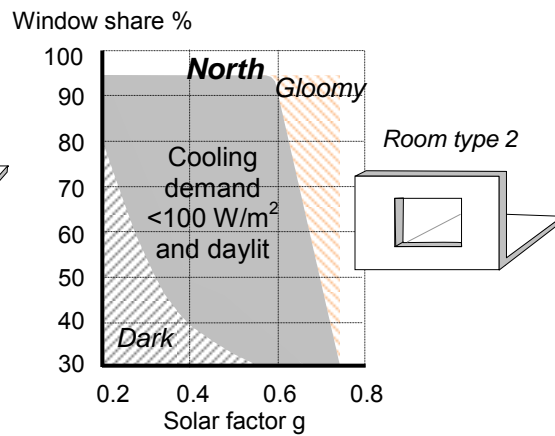
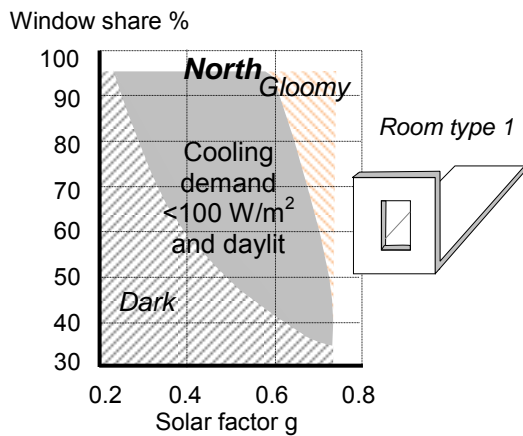
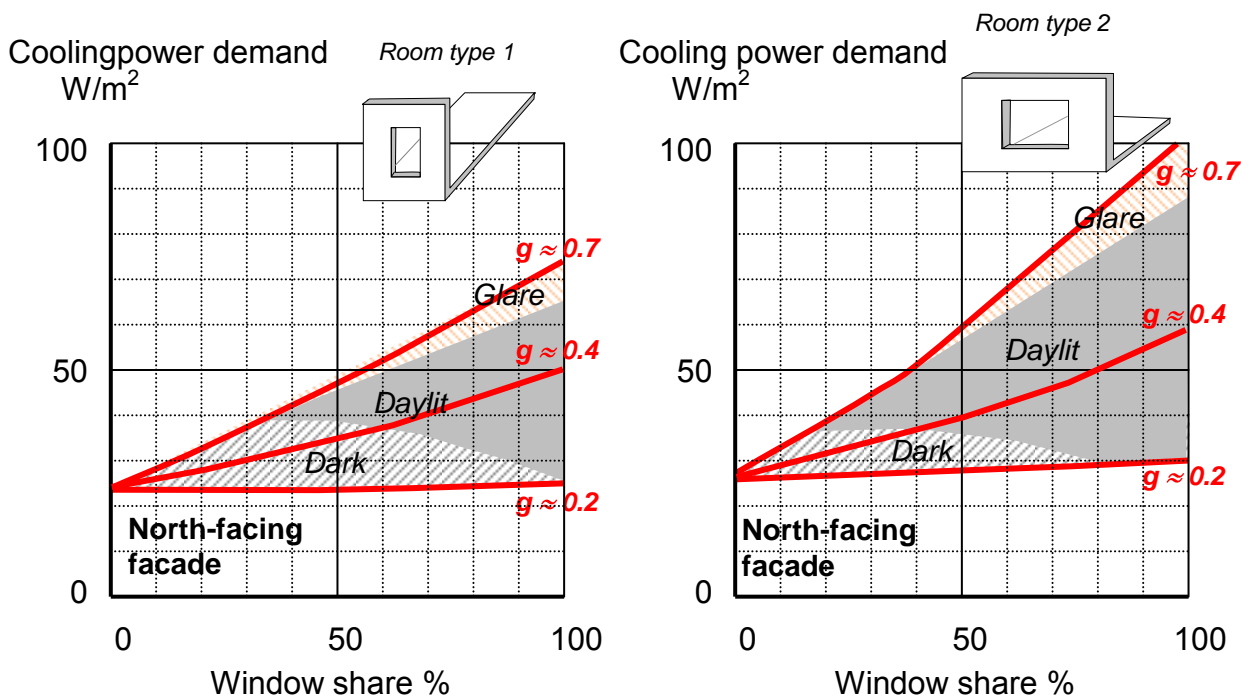

Figure 6 Possible window glass share and solar factor combination in rooms facing south for fulfilling the requirements: a cooling power demand below 100 W/m^2 , a daylight factor above 2 and a difference between the highest and lowest daylight factor less than 20.

Windows oriented north gives a wide range of possibilities to choose window shares and solar factors, as there is a little risk of exceeding high cooling power demands. However, using too small window shares or too low solar factors, or combinations of both, might result in a “dark” room. Using a too large window share would on the other hand might lead to gloomy rooms and result in a high heating power demand. South orientation has the highest cooling power demand and by that large window areas together with poor solar factors are not recommended to use because they might result in very high cooling power demands. For south orientations when the cooling power demand is below 100 W/m^2 there should not be any risk of a gloomy room caused of too large illuminance contrast during overcast days. The amount of window glass share possible for east and/or west facade is in between the results for north and south orientation when same cooling load and daylight requirements are considered.

By using daylight results from Table 2 and cooling power demand results from Figure 2, Figure 7 can be drawn. Here the cooling power demand is shown as a function of different window shares per facade with different solar factors (0.2; 0.4; 0.7) as parameters. Also here the area indicated “dark” means the daylight factor is below 2. The “daylit” area means the daylight factor is 2 or above. The “gloomy” area means the difference between the lowest and highest daylight factor is above 20. As north orientation does not get any direct solar radiation the cooling power demand is relatively low. That gives good opportunities to daylight designs without a resulting high cooling power demand. Even with a cooling power demand as low as 30 W/m^2 the daylight requirements could be fulfilled. South orientated rooms in general means a cooling power of about 80 W/m^2 or above to fulfil the daylight requirements.



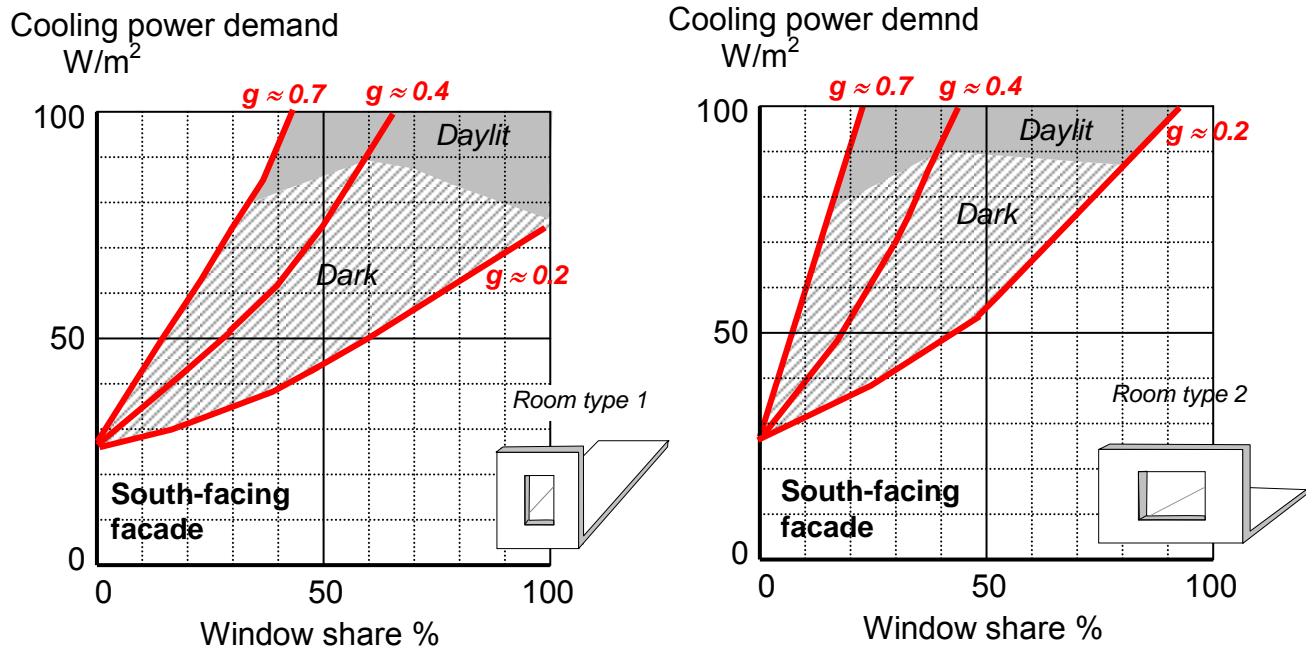

Figure 7 Room type 1 and 2 with a north and south facing facade. In each case a chilled beam system masters the heat surplus. The coloured zones indicate the daylight consequence on September overcast day.

The resulting cooling power demand for east and west orientations to fulfil the daylight requirement is in between the results for north and south. East oriented room means cooling

power demands above 55 W/m² and west oriented room above 65 W/m² to fulfil the daylight requirements.

5 Conclusion

There is a strong relation between the window share, the window solar factor and the design cooling power demand for an office room. However not many studies besides this have been focusing on all these aspects together. The study is carried out for two room types, both with 15 m² of floor area. Type 1 a rather typical office module with 9 m² of facade area and type 2 an office module that is a little more extreme regarding window size with 15 m² of facade area. The window share and the window solar factor for different orientations are connected in a way that the design cooling demand will be about similar for similar products of window share and window solar factor. Increasing window share and/or window solar factor results in increasing design cooling power demand.

Table 2 shows the maximum product of window share and window solar factor for both room types in order to keep the design cooling demand below a certain level.

The daylight availability is in general increasing with window share and window solar factor. The minimum product of window share and window solar factor for room type 1 to achieve a certain level of daylight is determined to be 0.24 and the corresponding value for room type 2 is 0.16. Furthermore, in order to avoid the risk of a gloomy room the product of window glass share and solar factor should not be larger than 0.33. Table 5 thus summarizes the feasible range of the product of window share and solar factor to utilize daylight in both room types for different maximum cooling power demand.

Table 5 Possible products of window share and solar factor for an office room type 1 for different maximum cooling power demands that also fulfill certain daylight requirements.

Cooling power demand, W/m ²	East		South		West		North	
	Room 1	Room 2	Room 1	Room 2	Room 1	Room 2	Room 1	Room 2
DF ≥ 2; 100 W/m ²	0.24-0.33	0.16-0.28	0.24-0.27	0.16-0.19	0.24-0.33	0.16-0.21	0.24-0.33	0.16-0.33
DF ≥ 2; 75 W/m ²	0.24-0.30	0.16-0.20	–	–	0.24-0.25	0.16	0.24-0.33	0.16-0.33
DF ≥ 2; 50 W/m ²	–	–	–	–	–	–	0.24-0.33	0.16-0.33

The final result, as shown in Table 5, indicates that it is difficult to utilize daylight and still have a low design cooling power demand (< 50 W/m²) based on the assumptions and requirements used in this study.

The study also gives an enhanced background to avoid designs with extreme cooling power

demands and poor daylight conditions. It is shown that a “daylit” design does not require an extreme window share per facade. In some circumstances even a window share of 30 – 40% per facade could fulfil the daylight requirements.

References:

- [1] Ternoey, S. (1999). *Daylight Every Building*, LightForms LCC.
- [2] Loveland, J. (2003). *Daylight By Design*, Lighting Design + Application, Magazine of the Illuminating Engineering Society of North America.
- [3] Veitch, J. (2006) *Lighting for High Quality Workplaces*, Creating the Productive Workplace, 2006, pp. 206-222
- [4] Abel, E., Elmroth, A., (2003). *Buildings and energy*. FORMAS, Stockholm 2007.
- [5] Voll, H. (2008). *Cooling Demand and Daylight in Commercial Buildings. The Influence of Window Design*, Chalmers University of Technology department of Energy and Environment. Pg 121. Göteborg.
- [6] Voll, H. (2005). *Cooling Demand in Commercial Buildings. The Influence of Building Design*, Chalmers University of Technology department of Energy and Environment. Pg 157. Göteborg.
- [7] Bergsten, B. (2004). *Free cooling in Commercial Buildings*, Chalmers University of Technology department of Building Technology. Pg 198. Göteborg.
- [8] Veitch, J., Gifford, R. (1996) *Assessing Lighting Effects on Health, Performane, Mood, and Social Behaviour*. Environment and Behaviour, 28(4), 446-470
- [9] Nabil, A., Mardaljevic, J. (2006) *Useful daylight illuminances: A replacement for daylight factors*. Institute of Energy and Sustainable Development, De Montfort University, The Gateway, Leicester LE1 9BH, UK
- [10] Abel, E. (2003). *The Energy Balance of a Building*. Book section of *Achieving the Desired Indoor Climate*. Editor Per Erik Nilsson. Studentlitteratur. The Commtech Group
- [11] Rundquist, R. (1984). *Simplified Window Energy Calculation Procedure..* ASHRAE research project 332-RP.
- [12] Fisk, W.J. (2000) *Health and Productivity Gains Better Indoor Environment*. Annual Review of Engineering and the Environment, 25, 537-566.
- [13] Roche, L., Dewey, E. (2000) *Occupant Reactions to Daylight Offices*. Lighting Research and Technology, 32(3), 119-126
- [14] Software BV2.
- [15] Abel, E. (2004) *Kontorihoone Kujustus, Kliimasysteem ja Energiatarbimine*. Pp5
- [16] Galasiu, A., Veitch, J., (2006) *Occupant Preferences and Satisfaction with the Luminous Environment and Control Systems in Daylit Offices: a Literature Review*. Energy and Building